

# GN 511 | Clamping kit for connecting clamps

Zinc alloy and stainless steel



- 1
- 2
- 3
- 4
- 5
- 6
- 7
- 8
- 9
- 10
- 11
- 12
- 13
- 14
- 15
- 16
- 17
- 18

## LEVER BODY

Die cast zinc alloy, epoxy resin coating.

## COLOUR

RAL 9006 silver.

## STANDARD EXECUTION

AISI 303 stainless steel clamping element with retaining screw.

AISI 301 stainless steel return spring.

AISI 303 stainless steel distance bushing.

## FEATURES AND APPLICATIONS

GN 511 clamping kit can be used as an alternative to the clamping screws supplied with the different kinds of connecting clamps.

The correspondent clamping kits are indicated in the tables of the different clamps.

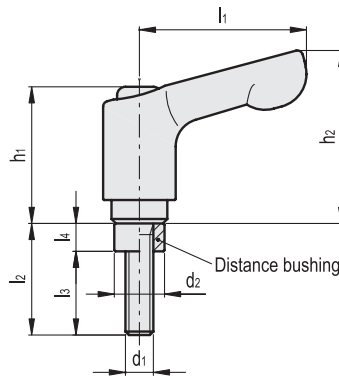

Conversion Table	
1 mm = 0.039 inch	
l2	
mm	inch
14	0.55
16	0.63
20	0.79
25	0.98
30	1.18
32	1.26



Code	Description	d1	d2	l1	l2	l3	l4	h1	h2	⚖
GN.23091	GN 511-M4-14	M4	7.5	30	14	9.5	4.5	24.5	30.5	34
GN.23092	GN 511-M4-16	M4	7.5	30	16	11.5	4.5	24.5	30.5	38
GN.23093	GN 511-M4-20	M4	7.5	30	20	15.5	4.5	24.5	30.5	40
GN.23094	GN 511-M5-16	M5	9	30	16	10	6	24.5	30.5	41
GN.23095	GN 511-M5-20	M5	9	30	20	14	6	24.5	30.5	43
GN.23096	GN 511-M5-25	M5	9	30	25	19	6	24.5	30.5	46
GN.23097	GN 511-M6-20	M6	10.5	45	20	13.5	6.5	24.5	35	40
GN.23098	GN 511-M6-25	M6	10.5	45	25	18.5	6.5	24.5	35	45
GN.23100	GN 511-M6-30	M6	10.5	45	30	23.5	6.5	24.5	35	51
GN.23099	GN 511-M6-32	M6	10.5	45	32	25.5	6.5	24.5	35	52

Leveling elements and supports